



# IMPORTANT NOTICE - READ CAREFULLY Natural Gas Inline Bypass Ball Vaves

**NOTE:** These valves are designed for use with natural, manufactured or LP gas only.

- Read instructions before valve installation or maintenance.
- Inspect valves for foreign material. Remove any foreign material, being careful not to damage the ball surface or the port seals.
- Valve should always be left in either the fully open or fully closed position.
- Always apply a quality grade pipe thread sealant to the pipe before installation - **DO NOT USE PTFE(TEFLON™) TAPE.** Excess pipe sealant contacting the ball surface may cause the valve to leak.
- Always use wrenching flats nearest to connection point. Never insert a tool into the ball area of the valve to thread it onto the pipe. Incorrect or over-tightening of the valve on installation can cause valve failure.
- Installation torques should be reduced when using pipe heavier than schedule 40.
- Follow all applicable codes and procedures.
- Shutoff plug should operate smoothly, **STOP OPENING IMMEDIATELY WHEN RESISTANCE IS FELT.**

\*Recommended procedure upon installation to ensure bypass shutoff plug is fully engaged.

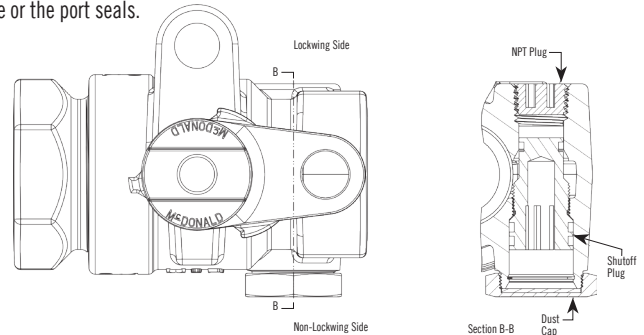

**STEP 1**

Remove the dust cap on the non-lockwing side of the inlet inline bypass ball valve.

**STEP 2**

Ensure the shutoff plug on non-lockwing side of inlet inline bypass ball valve is threaded in all the way. If the shutoff plug is not threaded all the way in, do so before proceeding.



# IMPORTANT NOTICE - READ CAREFULLY Natural Gas Inline Bypass Ball Vaves

**NOTE:** These valves are designed for use with natural, manufactured or LP gas only.

- Read instructions before valve installation or maintenance.
- Inspect valves for foreign material. Remove any foreign material, being careful not to damage the ball surface or the port seals.
- Valve should always be left in either the fully open or fully closed position.
- Always apply a quality grade pipe thread sealant to the pipe before installation - **DO NOT USE PTFE(TEFLON™) TAPE.** Excess pipe sealant contacting the ball surface may cause the valve to leak.
- Always use wrenching flats nearest to connection point. Never insert a tool into the ball area of the valve to thread it onto the pipe. Incorrect or over-tightening of the valve on installation can cause valve failure.
- Installation torques should be reduced when using pipe heavier than schedule 40.
- Follow all applicable codes and procedures.
- Shutoff plug should operate smoothly, **STOP OPENING IMMEDIATELY WHEN RESISTANCE IS FELT.**

\*Recommended procedure upon installation to ensure bypass shutoff plug is fully engaged.

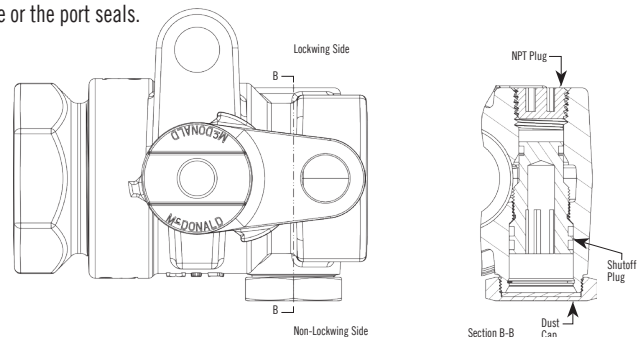

**STEP 1**

Remove the dust cap on the non-lockwing side of the inlet inline bypass ball valve.

**STEP 2**

Ensure the shutoff plug on non-lockwing side of inlet inline bypass ball valve is threaded in all the way. If the shutoff plug is not threaded all the way in, do so before proceeding.



## IMPORTANT NOTICE - READ CAREFULLY

# Natural Gas Inline Bypass Ball Vaves

**NOTE: These valves are designed for use with natural, manufactured or LP gas only.**

A.Y. McDonald's O-ring design insulated end assures positive sealing and long lasting service.

The **insulated end** is properly assembled to the valve by tightening the union nut hand tight plus 1/4 to 1/2 turns.

**CAUTION** - Excessive tightening could cause leakage.

The **non-insulating end** piece is properly assembled to the valve by tightening the union nut hand tight plus 1/4 to 1/2 turns.

If the O-ring is removed from the end piece, it can easily be replaced as follows:

1) Lay O-ring in groove - don't force it in with your fingers.

**CAUTION** - O-ring and groove must be free of foreign material. A coat of petroleum jelly should be applied to the O-ring after assembly.

2) Hand tighten the union nut onto the valve to uniformly press the O-ring into the groove.

3) This uniform pressure of the meeting of the valve and end piece will properly seat the O-ring.

### CAUTION

Soaps, solvents or fluids containing Glycol that are used for testing or cleaning the valve are **NOT** to have any contact with ball.

Never try to disassemble an A.Y. McDonald valve. If the valve is damaged or otherwise not functional, immediately remove the valve and replace it with a new one.



**WARNING:** It is unlawful in CALIFORNIA & VERMONT (effective 1/1/2010); MARYLAND (effective 1/1/2012); LOUISIANA (effective 1/1/2013) and the UNITED STATES OF AMERICA (effective 1/4/2014) to use any product in the installation or repair of any public water system or any plumbing in a facility or system that provides water for human consumption if the wetted surface area of the product has a weighted average lead content greater than 0.25%. This prohibition does not extend to service saddles used in California, Louisiana or under USA Public Law 111-380.



## IMPORTANT NOTICE - READ CAREFULLY

# Natural Gas Inline Bypass Ball Vaves

**NOTE: These valves are designed for use with natural, manufactured or LP gas only.**

A.Y. McDonald's O-ring design insulated end assures positive sealing and long lasting service.

The **insulated end** is properly assembled to the valve by tightening the union nut hand tight plus 1/4 to 1/2 turns.

**CAUTION** - Excessive tightening could cause leakage.

The **non-insulating end** piece is properly assembled to the valve by tightening the union nut hand tight plus 1/4 to 1/2 turns.

If the O-ring is removed from the end piece, it can easily be replaced as follows:

1) Lay O-ring in groove - don't force it in with your fingers.

**CAUTION** - O-ring and groove must be free of foreign material. A coat of petroleum jelly should be applied to the O-ring after assembly.

2) Hand tighten the union nut onto the valve to uniformly press the O-ring into the groove.

3) This uniform pressure of the meeting of the valve and end piece will properly seat the O-ring.

### CAUTION

Soaps, solvents or fluids containing Glycol that are used for testing or cleaning the valve are **NOT** to have any contact with ball.

Never try to disassemble an A.Y. McDonald valve. If the valve is damaged or otherwise not functional, immediately remove the valve and replace it with a new one.



**WARNING:** It is unlawful in CALIFORNIA & VERMONT (effective 1/1/2010); MARYLAND (effective 1/1/2012); LOUISIANA (effective 1/1/2013) and the UNITED STATES OF AMERICA (effective 1/4/2014) to use any product in the installation or repair of any public water system or any plumbing in a facility or system that provides water for human consumption if the wetted surface area of the product has a weighted average lead content greater than 0.25%. This prohibition does not extend to service saddles used in California, Louisiana or under USA Public Law 111-380.